

## EMPALMES MECÁNICOS UNIVERSALES 3M® Fibrlok®

El empalme mecánico Fibrlok es un accesorio universal, que posibilita la realización de empalmes en f.o. de una forma rápida y segura, en cualquier circunstancia, sin necesidad de aporte externo de energía, y a un coste reducido.



El empalme mecánico Fibrlok consiste básicamente en un cuerpo de material plástico de alta resistencia, en cuyo interior se encuentra una pieza metálica que garantiza un perfecto enfrentamiento y fijación de la fibra óptica. El empalme universal puede ser utilizado para fibra óptica monomodo o multimodo, con revestimiento de 125  $\mu\text{m}$  y recubrimiento de 900  $\mu\text{m}$  ó 250  $\mu\text{m}$

### Dimensiones exteriores:

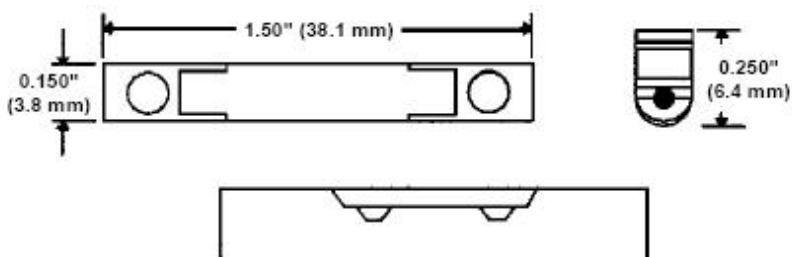

Vista de un Fibrlok antes y después de su accionamiento:  
 Antes de realizar la conexión, las fibras han de ser cortadas con precisión e introducidas en el Fibrlok. Utilizando el útil de conexión, se cierra la pinza del conector, y el elemento metálico posiciona adecuada y precisamente los extremos de las fibras.

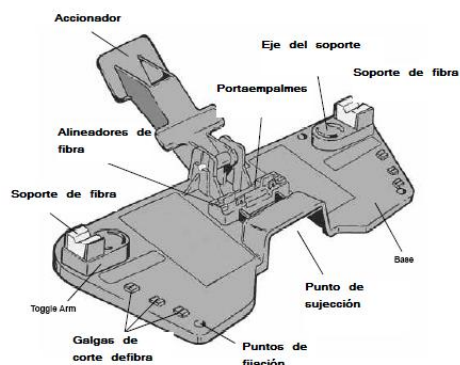
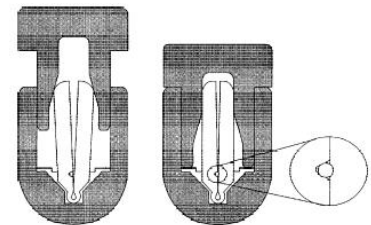

Especificaciones técnicas:

**Denominación :** Fibrlok ref 2529

**Diámetro de la fibra óptica:** 125 um

**Revestimiento:** 250 a 900 um

**Vida útil:** > 30 años

**Tiempo de ejecución:** < 30 seg. (una vez preparadas y cortadas las fibras)

**Pérdidas de inserción:** 0,1 dB (media)

**Pérdidas de retorno:** > 35 dB ( entre -40° C y 80 ° C ) ; > 60 dB (temp. media )

**Resistencia a la tracción:** > 4,5 N ( media 13 N)

**Material:** Plástico resistente a altas temperaturas, con elemento metálico de aluminio.

**Ámbito de temperatura:** -40°C a + 80 °C

Herramienta de inserción:

**Referencia:** 2501

Herramientas necesarias para la utilización del fibrlok:

- Util de inserción 2501
- Cortadora de precisión
- Herramientas de pelado y preparación de cable

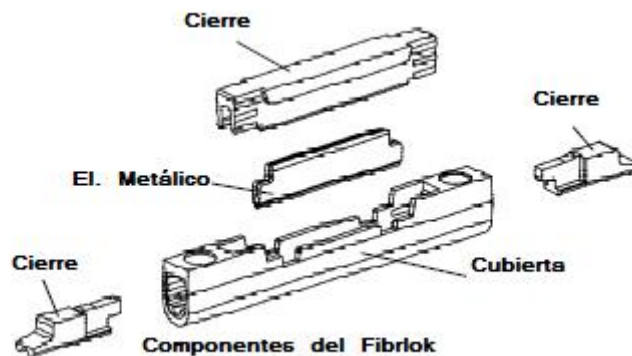

### KIT DE MONTAJE PARA EMPALME MECÁNICO FIBRLOK



#### Contenido del conjunto:

. Kit Fibrlok con cortadora, herramientas de ensamblado y muestras Fibrlok.

- Herramienta de ensamblado tipo 2501 para Fibrlok II
- Herramienta de ensamblado 2504-G para Fibrlok 4 x 4
- Peladora 6365-ST
- Tijeras
- Gasas y botella para alcohol
- Cortadora Isentech CI-01<sup>a</sup>
- Muestras de empalmes Fibrlok II, Fibrlok 4 x 4 y Fibrlok holder
- Bolsa con adaptador para herramienta 2501

#### Referencias de compra Fibrlok:

Referencia	Descripción
2529	Empalme mecánico universal (250-900 um) (Pack de 60)
2529B	Empalme mecánico universal (250-900 um) (Pack de 1000)
2540-G	Empalme Fibrlok Lite (4 x 4 mm.) para 250 um
2539	Soporte de empalme Splice holder con empalme Fibrlok
2599-H	Soporte para 6 empalmes Fibrlok para cassette DIN
2559-C	Kit Fibrlok con cortadora
2559	Kit Fibrlok sin cortadora



**3M**

Fibrlok™ II 2529

Universal Optical Fiber Splice

Technical Report

*December 1994*

*Issue 1, 78-8098-3415-9*

# 1.0 Product Description

The 3M brand Fibrlok™ II 2529 Universal Optical Fiber Splice is a high performance, easy-to-use, mechanical optical fiber splice. The Fibrlok II Universal Splice can be used with either single-mode or multimode fibers with a cladding diameter of 125 microns. It will accommodate any combination of fibers with coating diameters from 250 µm to 900 µm. In addition, the Universal Optical Fiber Splice incorporates a single cleave length for splicing both 250 and 900 micron coated fibers and provides the ability to "re-position" fibers for increased splicing yields.

The splice consists of four molded polymeric components and an aluminum alloy alignment element. The four polymeric components are: Jacket, End Plug (2), and Cap. The jacket is provided with a compartment to house the aluminum alloy element. The end plugs are attached to each end of the jacket and locate the element laterally within the splice jacket. Each splice end plug contains a fiber entry port which is used to guide either 250 or 900 micron coated optical fiber into the alignment element. During splice actuation, the cap acts on the element to align and secure the fibers within the splice.

The Fibrlok II Universal Optical Fiber Splice is an improved version of the original Fibrlok Optical Splice. The Universal Optical Fiber Splice element is constructed from the same ductile aluminum alloy as the original Fibrlok Splice element. All splice components are factory-assembled. An index matching gel is pre-installed in the splice element.

During assembly, the splice is held within the Fibrlok 2501 Assembly Tool. After the fibers are inserted into the splice, the cap is depressed with the Assembly Tool. The motion of the cap squeezes the "legs" of the element such that the "legs" come together. The fibers are permanently aligned and gripped in the fiber holding region of the splice when the cap is actuated.

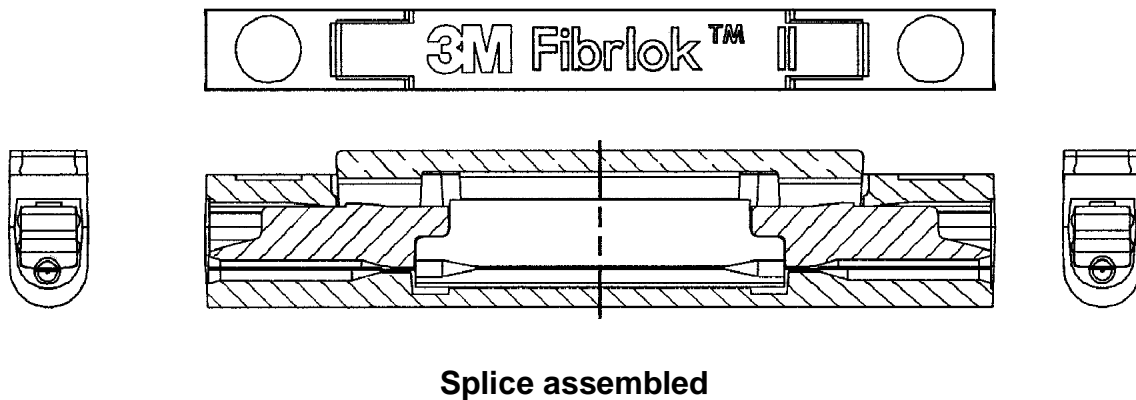
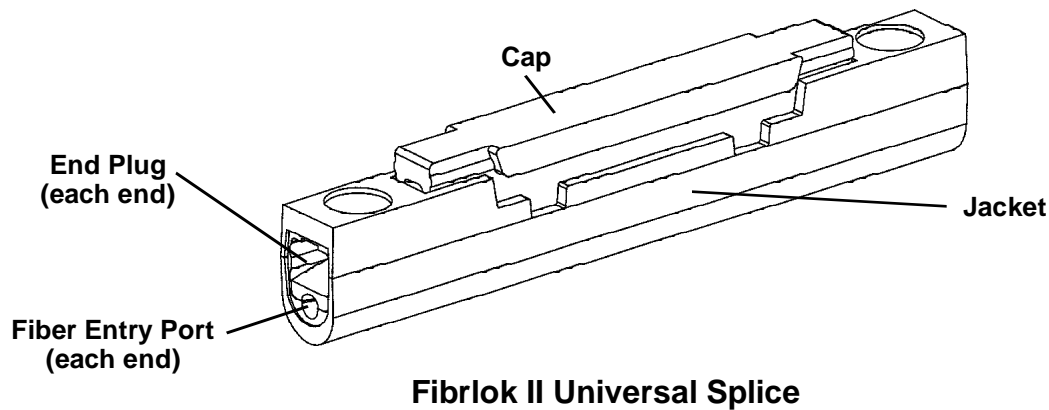

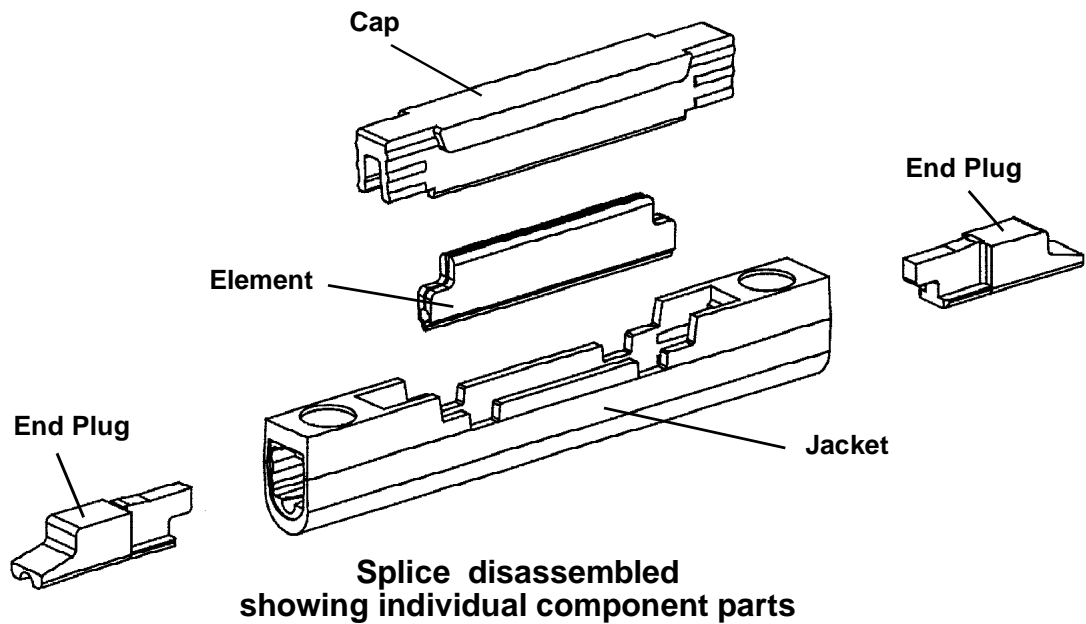

**Dimensions (actual size)**

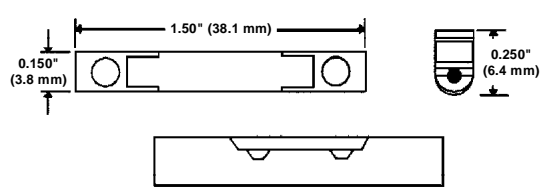

**Cross-sectional view of open and actuated Fibrlok II Universal Optical Fiber Splice**

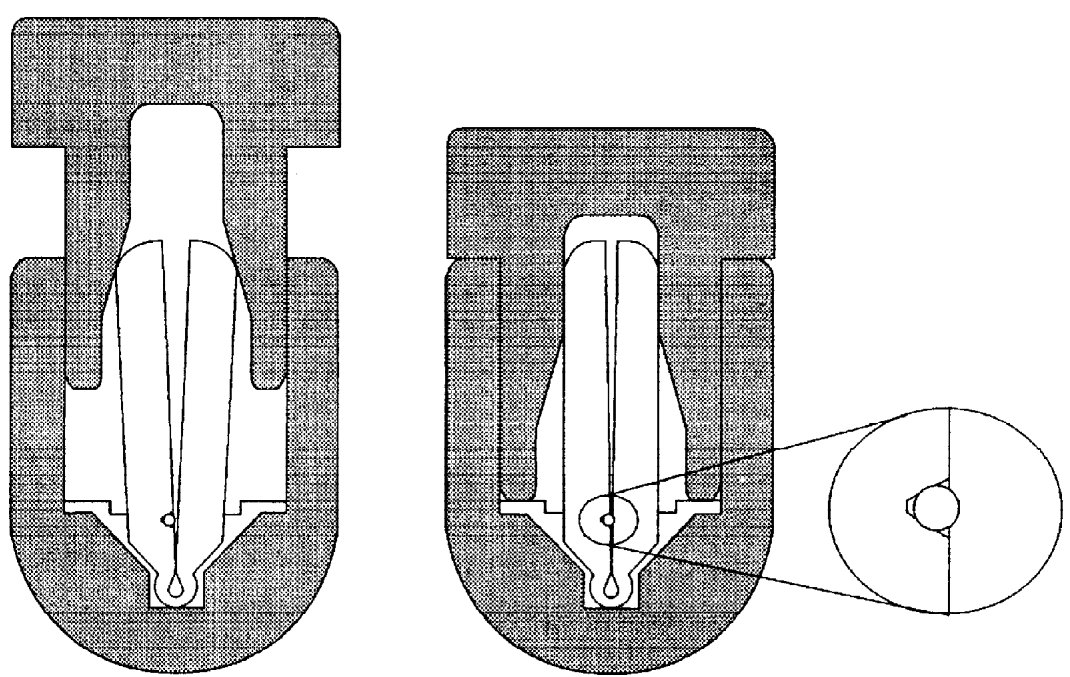

After preparation, the fibers are inserted into the Fibrlok II Splice element. The assembly tool is then used to close the the cap, forcing the clamping and locating surfaces against the fibers and aligning the fibers precisely and permanently in place.

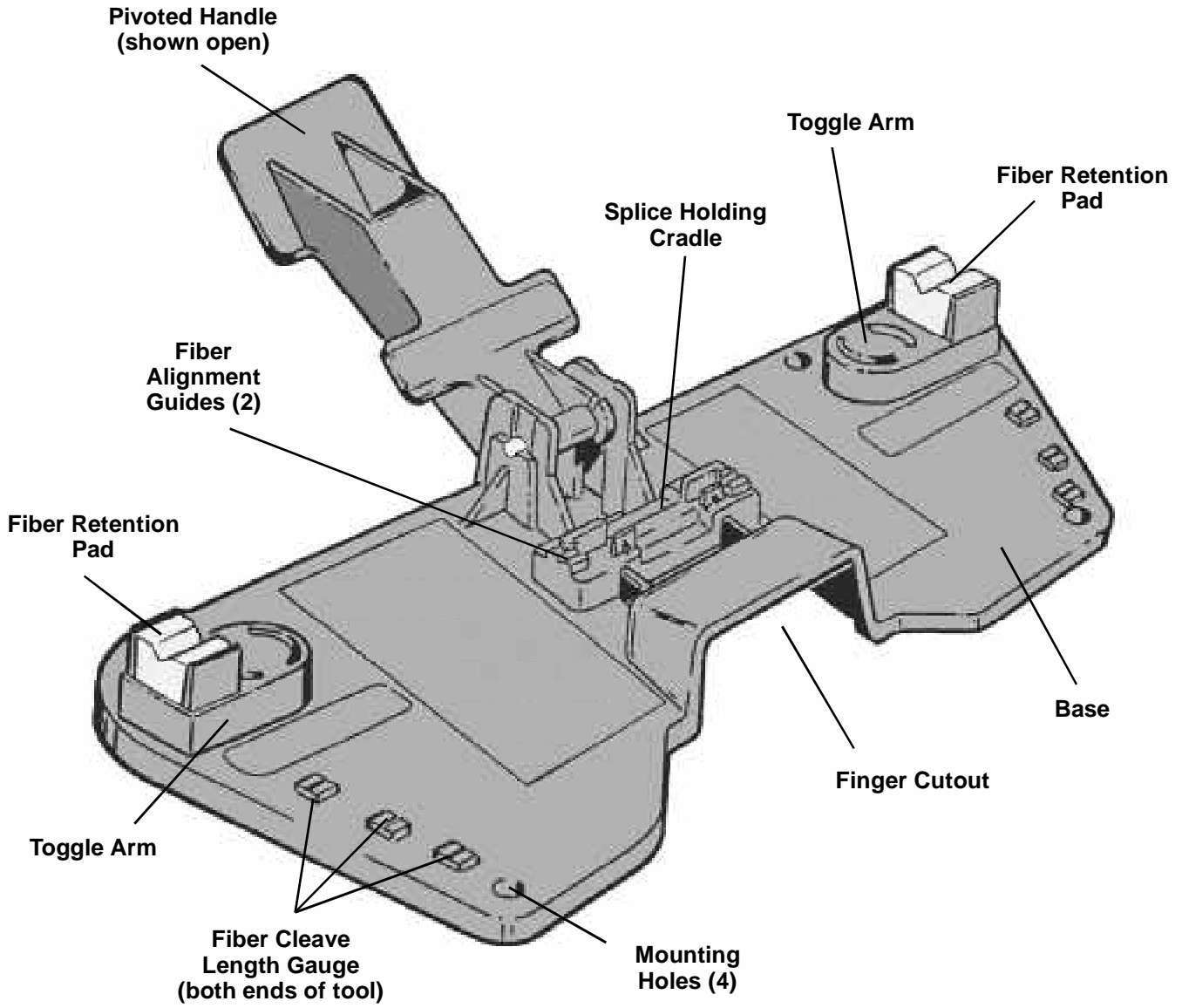

**Fibrlok 2501 Assembly Tool**

## 2.0 Test Program Overview

To assess the long term performance of the Fibrlok II Universal Optical Fiber Splice, the splices were subjected to a number of tests which expose them to conditions which are more severe than those which are anticipated in actual use.

The test samples used for all the tests were produced in the 3M Austin, Texas manufacturing facility. Testing of the splices occurred in the 3M Fiber Optics Test Laboratory in Austin. The tests are based upon telephone industry specifications and are believed to represent the most severe requirements in the industry.

The tests described in this Technical Report were conducted using Corning SMF-28™ 250 micron coated fiber and Fibrlok II 2529 Universal Optical Fiber Splices. All splice samples were constructed using "heterogeneous" optical fiber (fiber of the same type but different lots). Initial loss and reflectance was measured with a Tektronix Fibermaster TFP2 OTDR using a 100 ns pulse width and the fiber manufacturer's recommended backscatter coefficient.

All splices were prepared using square cleaves. A square cleave will provide worst case reflectance results.



### 3.0 Installation Conditions

The Installation Conditions testing is intended to analyze the actual operation of splicing fibers under a variety of installation conditions using high and low extremes for temperature and humidity.

Splices using single mode fiber were constructed under the following environmental conditions:

Test	Temperature	Relative Humidity
Low Temperature	0°C (32°F)	Uncontrolled
High Temperature	45°C (113°F)	15%
High Humidity	23°C (73°F)	90%
Low Humidity	23°C (73°F)	15%

#### Procedure:

Splices were constructed in a walk-in controlled environmental test chamber that was large enough to accommodate test personnel and splicing equipment. Splice loss and reflectance were measured using two-way OTDR measurements. Splices, fiber and splice assembly tools were all allowed to come to thermal equilibrium prior to splice assembly.

### 3.1 Summary of Results - Installation Conditions

"Conforming" splices are defined as splices which exhibit insertion loss of less than or equal to 0.20 dB, have a splice reflectance no greater than -40 dB, and are capable of withstanding a minimum tensile load of 4.4 N (1.0 lb-f). For each test condition, splices were constructed until 20 "conforming" splices had been obtained. Loss and reflectance for each "conforming" splice was measured using the OTDR.

Splice yield is defined as the number of "conforming" splices (i.e. 0.20 dB) divided by the total number of splices constructed.

Mean loss is the average splice loss (dB) of the twenty "conforming" splices constructed for each set of installation conditions.

Reflectance values listed represent minimum and maximum measured reflectance at the installation temperature. For additional information concerning the relationship between operating temperature and reflectance, refer to Appendix A.

### 3.2 Test Results for both 1310 nm and 1550 nm

1310 nm 250  $\mu$ m to 250  $\mu$ m

Test	Mean Loss	Max Loss	Splice Yield	Lowest Measured Reflectance	Highest Measured Reflectance
Low Temperature	0.08 dB	0.12 dB	100 %	-65.0 dB	-47.7 dB
High Temperature	0.08 dB	0.15 dB	100 %	-65.0 dB	-49.0 dB
High Humidity	0.12 dB	0.59 dB	91 %	-65.0 dB	-40.0 dB
Low Humidity	0.07 dB	0.16 dB	100 %	-65.0 dB	-58.0 dB

1310 nm 250  $\mu$ m to 900  $\mu$ m

Test	Mean Loss	Max Loss	Splice Yield	Lowest Measured Reflectance	Highest Measured Reflectance
Low Temperature	0.10 dB	0.44 dB	95 %	-65.0 dB	-48.5 dB
High Temperature	0.07 dB	0.17 dB	100 %	-65.0 dB	-47.2 dB
High Humidity	0.06 dB	0.15 dB	100 %	-65.0 dB	-64.0 dB
Low Humidity	0.07 dB	0.12 dB	100 %	-65.0 dB	-65.0 dB

1550 nm 250  $\mu$ m to 250  $\mu$ m

Test	Mean Loss	Max Loss	Splice Yield	Lowest Measured Reflectance	Highest Measured Reflectance
Low Temperature	0.10 dB	0.11 dB	100 %	-73.2 dB	-44.6 dB
High Temperature	0.07 dB	0.13 dB	100 %	-65.0 dB	-51.6 dB
High Humidity	0.09 dB	0.29 dB	91 %	-65.0 dB	-37.2 dB
Low Humidity	0.07 dB	0.14 dB	100 %	-65.0 dB	-55.7 dB

1550 nm 250  $\mu$ m to 900  $\mu$ m

Test	Mean Loss	Max Loss	Splice Yield	Lowest Measured Reflectance	Highest Measured Reflectance
Low Temperature	0.08 dB	0.37 dB	95 %	-65.0 dB	-45.0 dB
High Temperature	0.07 dB	0.11 dB	100 %	-65.0 dB	-48.6 dB
High Humidity	0.07 dB	0.16 dB	100 %	-65.0 dB	-58.0 dB
Low Humidity	0.06 dB	0.11 dB	100 %	-65.0 dB	-59.5 dB

## 4.0 Environmental Life Test Series

The Environmental Life Test Series is designed to analyze the life test performance of the splice including vibration, temperature cycling, water immersion, and environmental degradation (final tensile testing).

Prior to testing, the splices were placed in a vertical orientation and conditioned for 15 days at 60°C (140°F). Splices undergoing the Environmental Life Test Series were then spliced and subjected to the following sequential life tests as indicated below:

- 4.0.1 Initial Splice Loss and Splice Yield** – Fibrlok II Universal Splices were constructed until 30 splices were constructed with loss  $\leq 0.2$  dB. Splice yield was calculated by dividing the total number of conforming ( $\leq 0.2$  dB) splices by the number of splices made. Mean splice loss was calculated.
- 4.0.2 Splice Strength** – The 30 Fibrlok II Universal Splices were tested with a 4.4 N (1.0 lb-f) tensile load applied to the splice for five seconds, and the change in splice insertion loss was measured.
- 4.0.3 Vibration Splice Loss** – The 30 Fibrlok II Universal Splices were mounted in a Fibrlok 2524 Splice Organizer Tray, attached to a vibration test unit, and subjected to simple harmonic motion having an amplitude of 0.76 mm (0.03 inch) and 1.52 mm (0.06 inch) maximum total excursion. The vibration frequency was varied between 10 and 55 Hz. The entire frequency range, from 10 to 55 to 10 Hz, is traversed in approximately one minute. The splices were tested for two hours in each of three mutually perpendicular planes per EIA Standard FOTP 11, Condition I. Change in insertion loss during vibration was measured.
- 4.0.4 Temperature Cycling (100 cycles)** – The 30 Fibrlok II Universal Splices were subjected to temperature cycles (uncontrolled humidity) from -40°C to +80°C (-40°F to 176°F) with a temperature rate change of 2°C (3.6°F) per minute (one-hour transition time) and a two-hour dwell time at the temperature extremes. Loss and reflectance were measured during Temperature Cycling.
- 4.0.5 Water Immersion** – Following the completion of first 100 temperature cycles, splices were immersed in distilled water for 7 days at a temperature of 43°C (109°F). Splice loss and reflectance measurements at 23°C (73°F) were taken before water immersion and at one day after Water Immersion.
- 4.0.6 Temperature Cycling (100 cycles)** – Splices were temperature cycled for 100 additional cycles from -40°C to +80°C (-40°F to 176°F). Loss and reflectance were measured during Temperature Cycling.
- 4.0.7 Environmental Degradation** – A 4.4 N (1.0 lb-f) tensile load was applied to the splice for five seconds and change in loss was measured.

### 4.1 Summary of Results - Environmental Life Test Series

**Note:** *Measurement error for splice loss is estimated to be  $\pm 0.04$  dB. This experimental error should be applied when considering splice loss measurements for individual splice losses only and is not applied to statistical means.*

Reflectance values are reported as measured. No estimate of measurement error has been calculated for these values. Loss measurements were calculated bidirectionally. Reflection was measured in only one direction. Tensile testing was done with a fixture employing a Chatillon force gauge to monitor force.

Values are reported for measurements taken at 1310 nm and 1550 nm.

#### 4.1.1 Initial Splice Loss

After the splices were heat aged at 60°C (140°F) for 15 days, thirty "conforming" Fibrlok II Universal Splices were constructed for testing in the Environmental Life Test Series. Of the splices prepared for this sample group, mean splice loss was 0.05 dB at 1300 nm and 0.04 dB at 1550 nm. Splice yield for this sample group was 100%.

**4.1.1 – 4.1.7 Summary of Results (250 μm to 250 μm)**

Section	Test	Wavelength	Mean Loss	Max Loss	Mean Change in Loss	Average Reflectance	Maximum Reflectance
4.1.1	<b>Initial Splice Loss</b> (100% Yield)	1300 nm	0.05 dB	0.19 dB	N/A	-63.7 dB	-54.3 dB
		1550 nm	0.04 dB	0.13 dB	N/A	-59.7 dB	-51.8 dB
4.1.2	<b>Splice Strength</b>	1300 nm	0.05 dB	0.21 dB	0.00 dB	-63.9 dB	-55.1 dB
		1550 nm	0.05 dB	0.16 dB	0.01 dB	-58.6 dB	-52.4 dB
4.1.3	<b>Vibration</b>	1300 nm	0.05 dB	0.18 dB	0.00 dB	-63.9 dB	-55.1 dB
		1550 nm	0.05 dB	0.17 dB	0.01 dB	-52.0 dB	-52.2 dB
4.1.4	<b>Temp Cycle</b> (100 cycles)	1300 nm @ -40°C	0.05 dB	0.17 dB	-0.01 dB	-39.6 dB	-37.2 dB
		@ +23°C	0.05 dB	0.19 dB	0.00 dB	-63.8 dB	-54.6 dB
		@ +80°C	0.05 dB	0.18 dB	0.00 dB	-41.0 dB	-38.0 dB
		1550 nm @ -40°C	0.03 dB	0.13 dB	-0.01 dB	-38.7 dB	-35.1 dB
		@ +23°C	0.05 dB	0.15 dB	0.01 dB	-62.5 dB	-51.8 dB
		@ +80°C	0.03 dB	0.13 dB	-0.01 dB	-40.3 dB	-37.5 dB
4.1.5	<b>Water Immersion</b>	1300 nm @ +23°C	0.05 dB	0.19 dB	0.00 dB	-64.4 dB	-57.6 dB
		1550 nm @ +23°C	0.04 dB	0.15 dB	-0.01 dB	-61.4 dB	-54.6dB
4.1.6	<b>Temp Cycle</b> (200 cycles)	1300 nm @ -40°C	0.05 dB	0.19 dB	0.00 dB	-39.5 dB	-37.0 dB
		@ +23°C	0.05 dB	0.20 dB	0.00 dB	-57.6 dB	-54.5 dB
		@ +80°C	0.05 dB	0.19 dB	-0.01 dB	-40.9 dB	-37.7 dB
		1550 nm @ -40°C	0.03 dB	0.14 dB	-0.02 dB	-38.6 dB	-35.3 dB
		@ +23°C	0.05 dB	0.15 dB	0.01 dB	-62.3 dB	-55.3 dB
		@ +80°C	0.03 dB	0.15 dB	-0.01 dB	-40.5 dB	-37.4 dB
4.1.7	<b>Environmental Degradation</b>	1300 nm	0.05 dB	0.20 dB	0.00 dB	-64.3 dB	-57.5 dB
		1550 nm	0.05 dB	0.15 dB	0.01 dB	-62.7 dB	-54.7 dB

**Notes:** *During the Environmental Degradation Test, two fibers broke outside of the splice and were not included in the loss and reflection calculations for this test.*

*The average reflectance of the test samples at +23°C is less than reported above. The measured reflectance is limited by the test system's capability to measure small reflectances. For additional information concerning the relationship between operating temperature and reflectance, refer to Appendix A.*

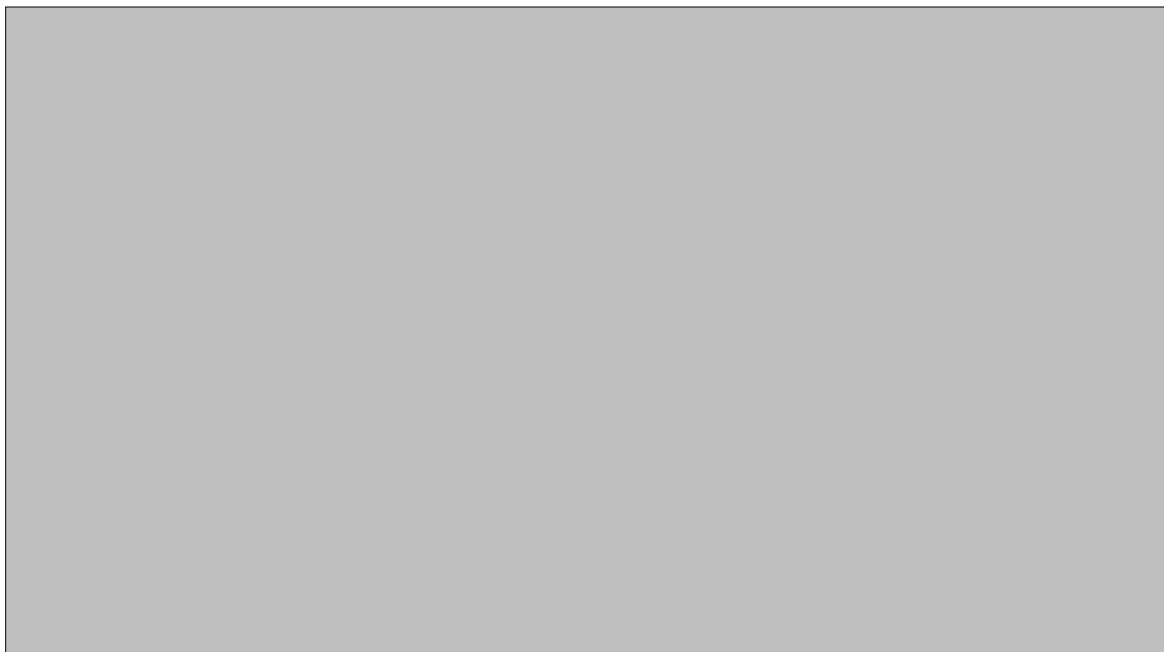

## 5.0 Conclusion

The Fibrlok II 2529 Universal Optical Fiber Splice represents an extension of the original Fibrlok Splice malleable, metallic splice element technology. Through this test program, the Fibrlok II Splice has met or exceeded the performance levels established by the original Fibrlok Splice.

The test results described in this report demonstrate the high yield, environmentally stable, low reflectance and low insertion loss characteristics of the Fibrlok II Universal Splice. The performance demonstrated by the Fibrlok II Splice assures a permanent, reliable splice for telecommunication applications.

## 6.0 APPENDIX A

### Relationship Between Temperature and Splice Reflectance

Reflections are caused by differences in the index of refraction (IOR) at the interface of two materials (e.g. fiber and index matching gel). Fibrlok II Splices contain an index matching gel with an IOR that is matched very closely to the IOR of the fiber at room temperature, 23° C (73°F).

The index of refraction of any material changes with the temperature of that material. As temperatures approach the operating temperature extremes of the Fibrlok II Splice, the difference between the IOR of the glass fiber and the index gel increases. This results in a variation in reflectance with temperature.

The relationship between temperature and reflectance for Fibrlok II Splices is shown in the graph below. The graph shows the actual and average reflectance values, at various operating temperatures, of 8 Fibrlok II Splices. As expected, reflectances are lowest at moderate temperatures where the index of refraction of the gel best matches that of the fiber.

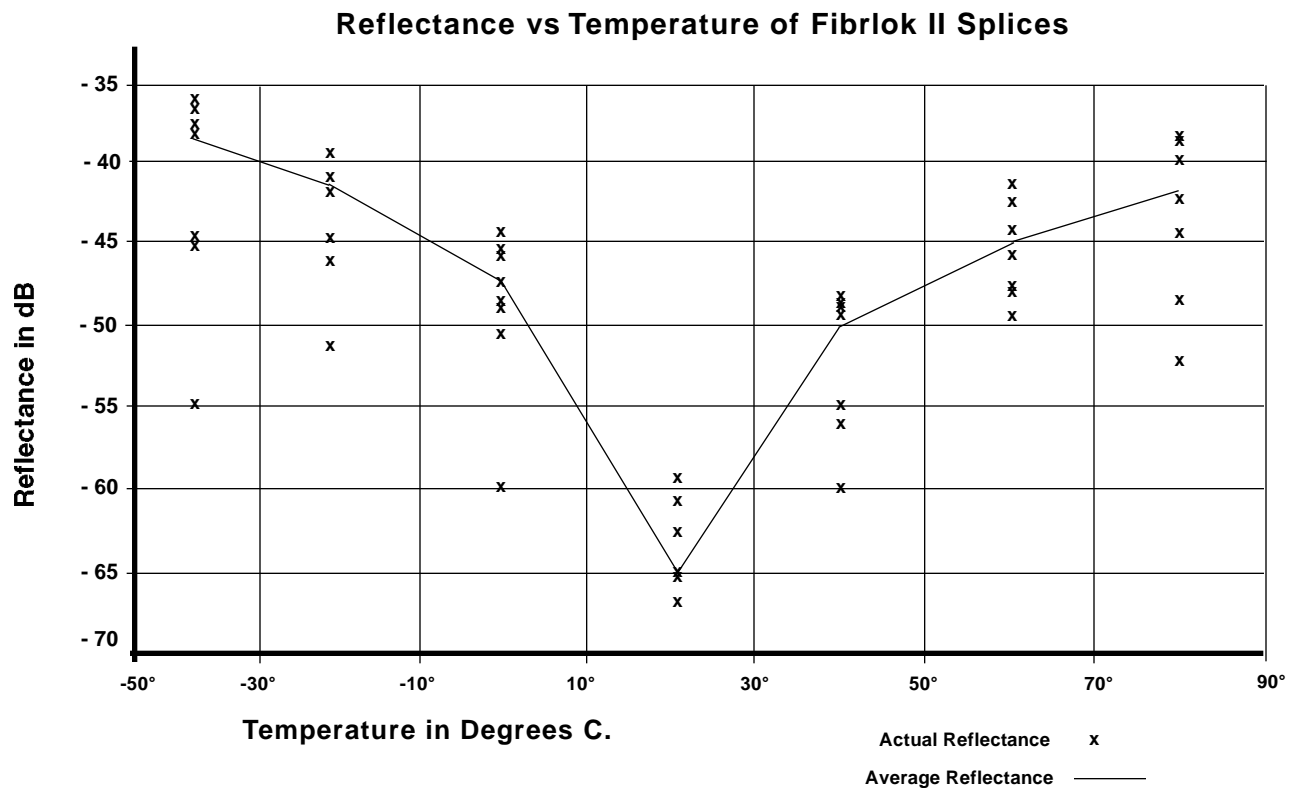

**Notes:** All splices were assembled with fiber cleave angles  $\ll 1$  degree in order to maximize reflectances at the various operating temperatures.

The average reflectance indicated was calculated from the average power of the 8 splices (i.e. the linear average).

**Important Notice**

All statements, technical information and recommendations related to the Seller's products are based on information believed to be reliable, but the accuracy or completeness thereof is not guaranteed. Before utilizing the product, the user should determine the suitability of the product for its intended use. The user assumes all risks and liability whatsoever in connection with such use.

Any statements or recommendations of the Seller which are not contained in the Seller's current publications shall have no force or effect unless contained in an agreement signed by an authorized officer of the Seller. The statements contained herein are made in lieu of all warranties, express or implied, including but not limited to the implied warranties of merchantability and fitness for a particular purpose which warranties are hereby expressly disclaimed.

SELLER SHALL NOT BE LIABLE TO THE USER OR ANY OTHER PERSON UNDER ANY LEGAL THEORY, INCLUDING BUT NOT LIMITED TO NEGLIGENCE OR STRICT LIABILITY, FOR ANY INJURY OR FOR ANY DIRECT OR CONSEQUENTIAL DAMAGES SUSTAINED OR INCURRED BY REASON OF THE USE OF ANY OF THE SELLER'S PRODUCTS THAT WERE DEFECTIVE.

**Telecom Systems Division**

6801 River Place Blvd.  
Austin, TX 78726-9000  
800/426-8688



*Printed on 50% recycled paper  
with 10% post-consumer*

Printed in USA  
© 3M 1994 78-8098-3415-9